



**- MANUAL DRIVEN -**

**Operating Instructions  
and Parts List for  
Series 30000  
Hose Reels**



**- POWER DRIVEN -**

**SAFETY PRECAUTIONS**

Personal injury and/or equipment damage may result if proper safety precautions are not observed.

- Ensure that the reel has been properly installed before connecting supply line (see installation instructions).
- Bleed fluid/gas pressure from system before servicing reel.
- Before connecting reel to supply line ensure that supply line pressure does

not exceed maximum rated working pressure of reel.

- Do not play pranks on other personnel. Even low pressure is very dangerous and can cause irreparable damage or death.
- Do not wear loose fitting clothing while operating reel.
- Be aware of other personnel in work area.
- Be aware of other machinery in work area.

- If a leak occurs in the hose or reel, remove supply line pressure immediately.
- If the reel is power driven check for loose, frayed, and/or broken wires before operating.
- Treat and respect a hose reel as any other piece of machinery, observing all common safety practices.

**IMPORTANT**  
**READ THIS MANUAL CAREFULLY BEFORE INSTALLING,  
 OPERATING OR SERVICING THIS EQUIPMENT**

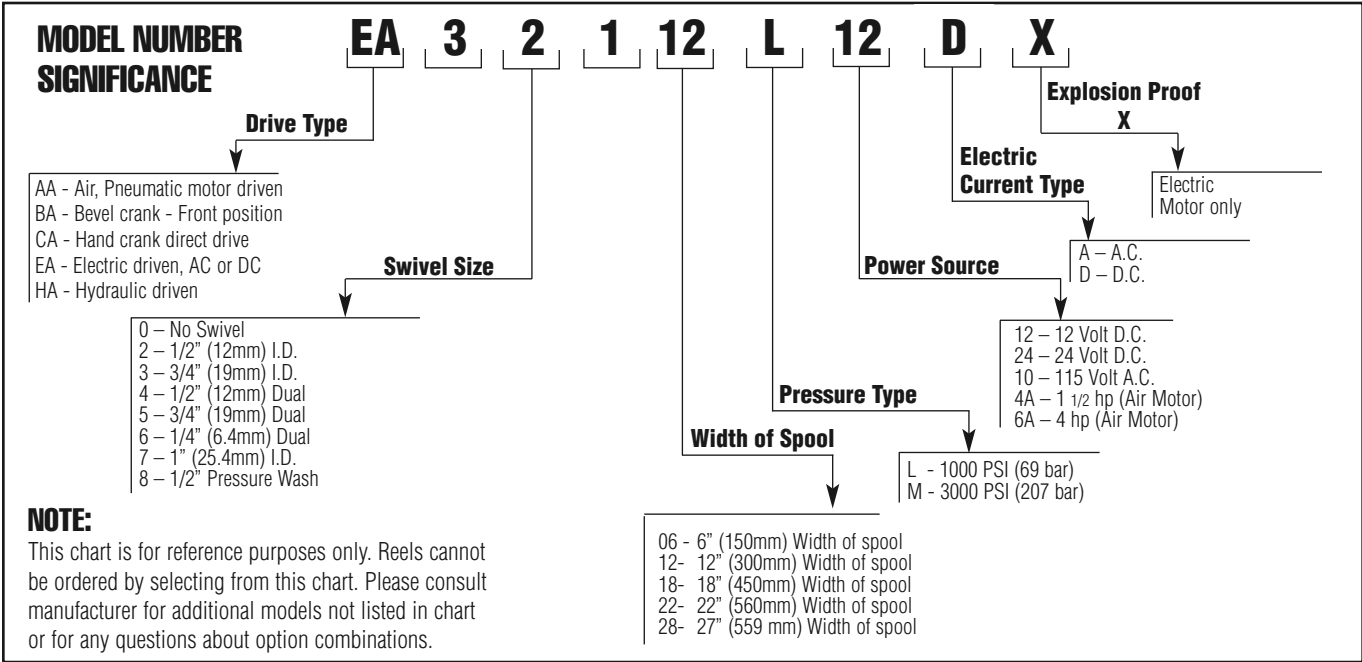

**DIMENSIONAL DATA**

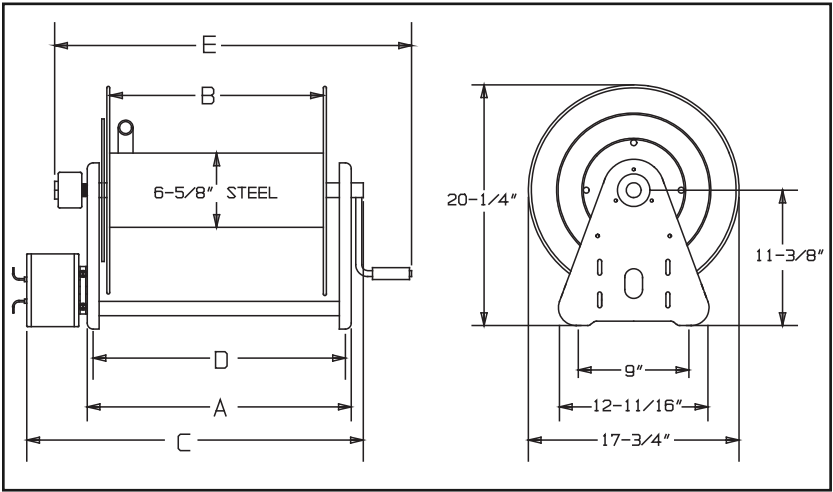

Part Number	A	B	C	D	E
EA33006 M12D	11"	6"	19"	19 3/4"	---
EA33112 M12D	17"	12"	25 1/4"	15 3/4"	---
EA33118 M12D	23"	18"	31 1/4"	21 3/4"	---
EA33122 M12D	27"	22"	35 1/4"	25 3/4"	---
EA33128 M12D	22"	27"	40 1/4"	30 3/4"	---
EA33106 M10A	11"	6"	19"	9 3/4"	---
EA33112 M10A	17"	12"	25 1/4"	15 3/4"	---
EA33118 M10A	23"	18"	31 1/4"	21 3/4"	---
EA33122 M10A	27"	22"	35 1/4"	25 3/4"	---
EA33128 M10A	32"	27"	40 1/4"	30 3/4"	---
AA33106 M4A	11"	6"	19"	9 3/4"	---
AA33112 M4A	17"	12"	25 1/4"	15 3/4"	---
AA33118 M4A	23"	18"	31 1/4"	21 3/4"	---
AA33122 M4A	27"	22"	35 1/4"	25 3/4"	---
AA33128 M4A	32"	27"	40 1/4"	30 3/4"	---
AA33106 M6A	11"	6"	19"	9 3/4"	---
AA33112 M6A	17"	12"	25 1/4"	15 3/4"	---
AA33118 M6A	23"	18"	31 1/4"	21 3/4"	---
AA33122 M6A	27"	22"	35 1/4"	25 3/4"	---
AA33128 M6A	32"	27"	40 1/4"	30 3/4"	---
CA33106 M	11"	6"	---	9 3/4"	19"
CA33112 M	17"	12"	---	15 3/4"	25"
CA33118 M	23"	18"	---	21 3/4"	31"
CA33122 M	27"	22"	---	25 3/4"	35"
CA33128 M	32"	27"	---	30 3/4"	40"

## INSTALLATION INSTRUCTIONS

### Inspection

Unpack and inspect the reel for damage. Turn the reel by hand to check for smooth operation. Check for completeness.

### Mounting of all hose reels

**NOTE:** Ensure that mounting surface is flat to prevent binding on reel after it is mounted.

1. Two 1/2" diameter mounting holes are located at the base of each side support panel (2 each). Mount reel using four (customer supplied) bolts; tightening them securely to ensure a solid, rigid attachment.

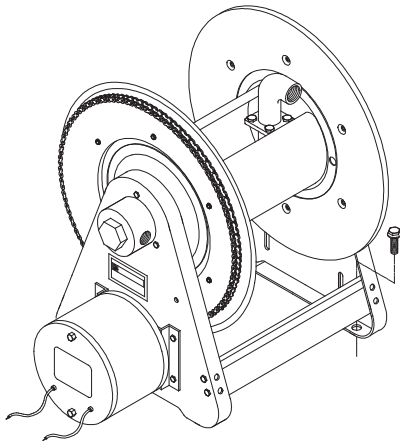

2. Perform the following steps only after all other installation steps, pertaining to your particular reel, are accomplished. Refer to page 4 for special instructions.

**NOTE:** A flexible hose connection must be used to compensate for any offset between the supply line and the reel swivel.

3. Apply thread compound to all threads.
4. Thread male connector of supply line into swivel. Tighten securely.

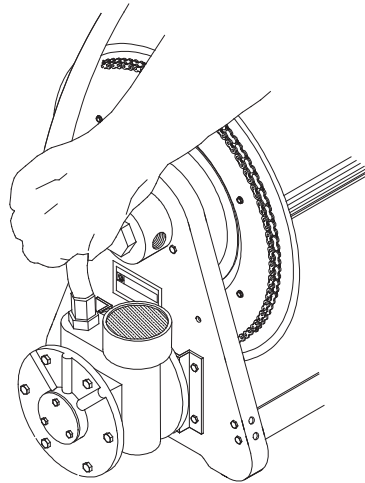

### Manual Driven Reels

Additional mounting instructions are not required.

### Power Driven Reels

1. Determine which end of reel motor is mounted on. If the original factory configuration is not conducive to your application, see section in the manual titled "Modifications".

**CAUTION:** Remove all electrical power when wiring. Do not "hot-wire". Observe all applicable NEC/OSHA requirements.

2. Ensure that supply and motor voltage ratings are compatible.
3. Consult wiring diagrams and determine which one is applicable to your reel.
4. Perform electrical wiring following applicable diagram.

## Wiring Diagrams

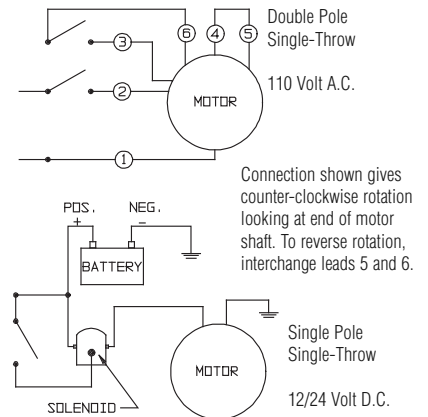

### Air Driven Reels

1. Determine which end of reel, motor is to be mounted on. If the original factory configuration is not conducive to your application see section in the manual titled, "Modifications".

**WARNING:** Do not exceed 100 PSI motor inlet pressure. Use an FRL or control valve in line to adjust speed of motor.

2. Connect air line to motor in accordance with diagram.

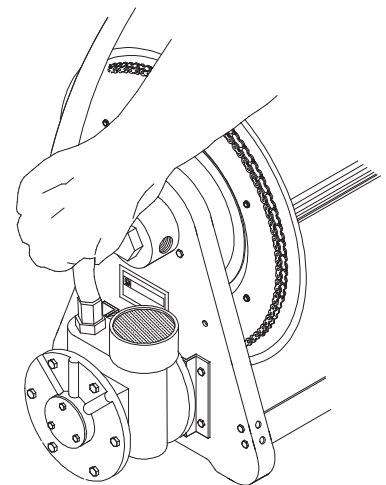

## Connecting the hose

**CAUTION:** Do not connect the hose to the connecting tube assembly until after hose reel has been installed. Fully extend and charge hose before winding on of reel. Momentarily open control valve, when initially charging, to purge hose of gases. When fluid appears at control valve, close valve. This prevents flattening of the hose and excessive pressure on the drum when fluid supply is reinitialized at a later time.

1. Apply thread compound to all threads.
2. Hand thread male hose connector into connecting tube assembly.
3. Using a wrench, firmly hold onto connecting tube assembly while tightening hose connector.

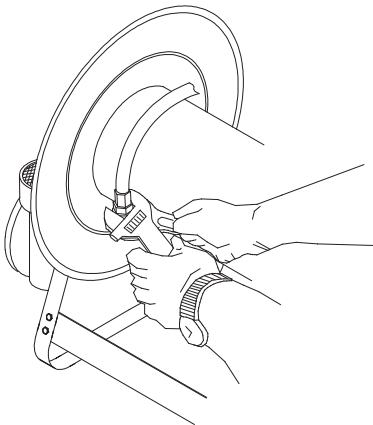

Pull hose from the reel by grasping the hose itself, not the control handle or swivel.

## SERVICE INSTRUCTIONS

### Replacing the hose

1. Using a wrench, firmly hold onto the connecting tube assembly while removing hose connector.
2. Follow procedures for "Connecting the hose" (refer to installation instructions).

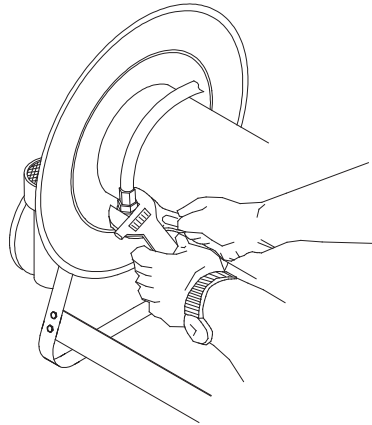

3. Install swivel assembly to inlet shaft by reversing steps 1 and 2. Apply thread compound to all threads.

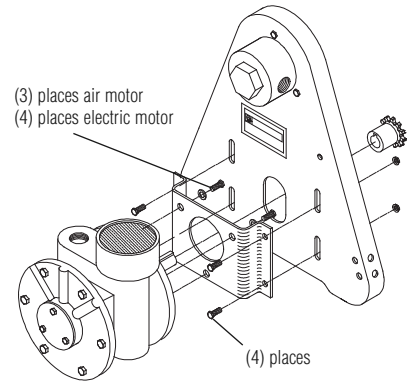

### Replacing the chain

**CAUTION:** Before replacing the chain, remove all electrical power (power driven) or air pressure (air driven) from motor.

1. Loosen (do not remove) bolts securing motor mounting bracket in place.
2. Remove chain master-link.
3. Remove chain master-link. Install new chain by reversing steps 1 and 2 above.

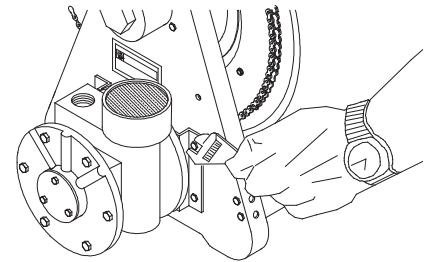

## OPERATING INSTRUCTIONS

### WARNING-PREVENT STATIC

**SPARKING:** When working around flammable liquids such as solvents, paints, chemicals or petroleum products, ensure that the hose reel, hose and the equipment being serviced are properly grounded. Use grounded hose(s) (static wire). Use an ohmmeter to check continuity of the ground circuit. Fire and/or explosion can result if proper grounding is not achieved. If reel is power or air driven, be careful of chain/sprocket drive system. Keep hands clear. Do not wear loose fitting clothing.

### Replacing the swivel

**CAUTION:** Remove supply line pressure before performing the following procedure.

1. Remove supply line from swivel.
2. Remove swivel assembly from inlet shaft.
3. Install swivel assembly to inlet shaft by reversing steps 1 and 2. Apply thread compound to all threads.

### Replacing the motor

**CAUTION:** Before replacing the motor, remove all electrical power (power driven) or air pressure (air driven) from motor.

1. Disconnect wiring/air lines from motor.
2. Remove bolts securing motor mounting bracket to reel. Remove bracket (refer to diagram on page 5).

## ADJUSTMENT PROCEDURES

### Adjusting the reel

1. Adjust reel drag by loosening or tightening set screw on hub casting on manual driven reel.

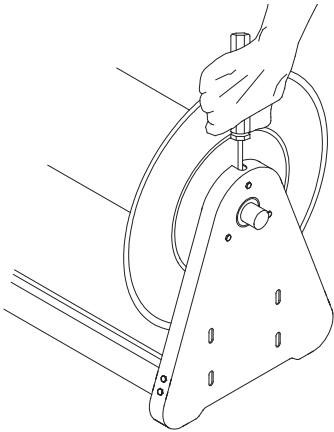

### Adjusting the chain tension

**CAUTION:** Before adjusting the chain tension, remove all electrical power (power driven) or air pressure (air driven) from motor. Over-tensioned (tightening) of chain results in reduced motor life. Adjust to allow between 1/4 and 1/2 inch play in chain.

1. Loosen bolts (do not remove) securing motor mounting bracket to reel.
2. Move motor mounting bracket and motor until proper chain tension is obtained.
3. Tighten motor mounting bracket bolts.

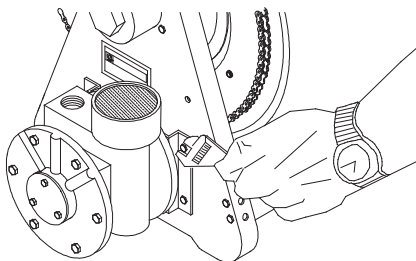

## MODIFICATIONS

**CAUTION:** Remove electrical reel power and release all pressure from hoses before beginning any modification.

### Motor mounting

If it is desired that the motor be mounted on the opposite end of the hose reel:

1. Remove bolts securing motor mounting bracket and sprocket to reel assembly.
2. Assemble components to other end of reel.

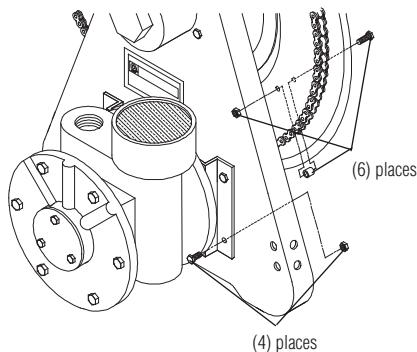

### Hand crank to motor driven conversion

It is possible to convert a manual driven hose reel to a power or air driven type. Contact Reelcraft customer service for information.



*Wind Things Up With Reelcraft*

**Parts common to all Series 30000 hose reels**

ITEM	DESCRIPTION	QTY.	XX3XX06	XX3XX12	XX3XX18	XX3XX22	XX3XX28
2	Screw, 5/16-12 x 5/8"	9	S317-31	S317-31	S317-31	S317-31	S317-31
3	Side frame	2	260403	260403	260403	260403	260403
5	Nut, 5/16-18	8	S85-7	S85-7	S85-7	S85-7	S85-7
6	Spool flange	2	260399-3	260399-3	260399-3	260399-3	260399-3
7	Snap ring	4	300007	300007	300007	300007	300007
11	Tie rod	4	260402-100	260402-200	260402-300	260402-400	260402-500
12	Spacer	4	260401-1	260401-2	260401-3	260401-4	260401-5
15	Lock handle ass'y	1	280109	280109	280109	280109	280109
20	Screw, 5/16-18 x 1/2"	8	S2-51	S2-51	S2-51	S2-51	S2-51
21	Nut, 5/16-18	8	300107	300107	300107	300107	300107
22	Cross brace	2	261501-1	261501-2	261501-3	261501-4	261501-5

**Parts common to single outlet Series 30000 hose reels**

ITEM	DESCRIPTION	QTY.	XX301XX	XX321XX L	XX321XX M	XX331XX	XX331XX L	XX381XX M
1	Swivel assembly	1	None	600822-2	600596-2	600599-2	600822-3	600596-3
8	Inlet assembly	1	600327-2	600327-2	600327-2	600327-2	600327-2	600327-2
9	O-ring	1	S211-120	S211-120	S211-120	S211-120	S211-120	S211-120
10	Screw, 5/16-18 x 3/4"	4	S7-51	S7-51	S7-51	S7-51	S7-51	S7-51
13	Hub & bushing ass'y	3	600640	600640	600640	600640	600640	600640
19	Support shaft	1	260770	260770	260770	260770	260770	260770
24	Screw, 1/4-20 x 5/8"	3	S2-42	S2-42	S2-42	S2-42	S2-42	S2-42

**Parts common to dual outlet Series 30000 hose reels**

ITEM	DESCRIPTION	QTY.	XX341XX L	XX341XX M	XX351XX	XX3XX06	XX3XX12	XX3XX18	XX3XX22	XX3XX22
1	Swivel assembly	2	600822-2	600596-2	600596-2	---	---	---	---	---
8	Inlet shaft assembly	1	---	---	---	600189-1	600189-2	600189-3	600189-4	600189-5
14	Set screw	2	---	---	---	300006	300006	300006	300006	300006
23	Reducer bushing	4	S174-109	S174-109	---	---	---	---	---	---
24	Screw, 1/4-20 x 5/8"	3	S318-48	S318-48	S318-48	S2-42	S2-42	S2-42	S2-42	S2-42

**Parts common to manual driven Series 30000 hose reels**

ITEM	PART NO.	DESCRIPTION	QTY.
4	300099	Set screw 3/8 brass	1
14	300006	Set screw, 3/8-16 x 1/2"	1
16	300089	Set screw 3/8 square head	1
17	S137-4	Snap ring	1
18	600102	Crank handle assembly	1

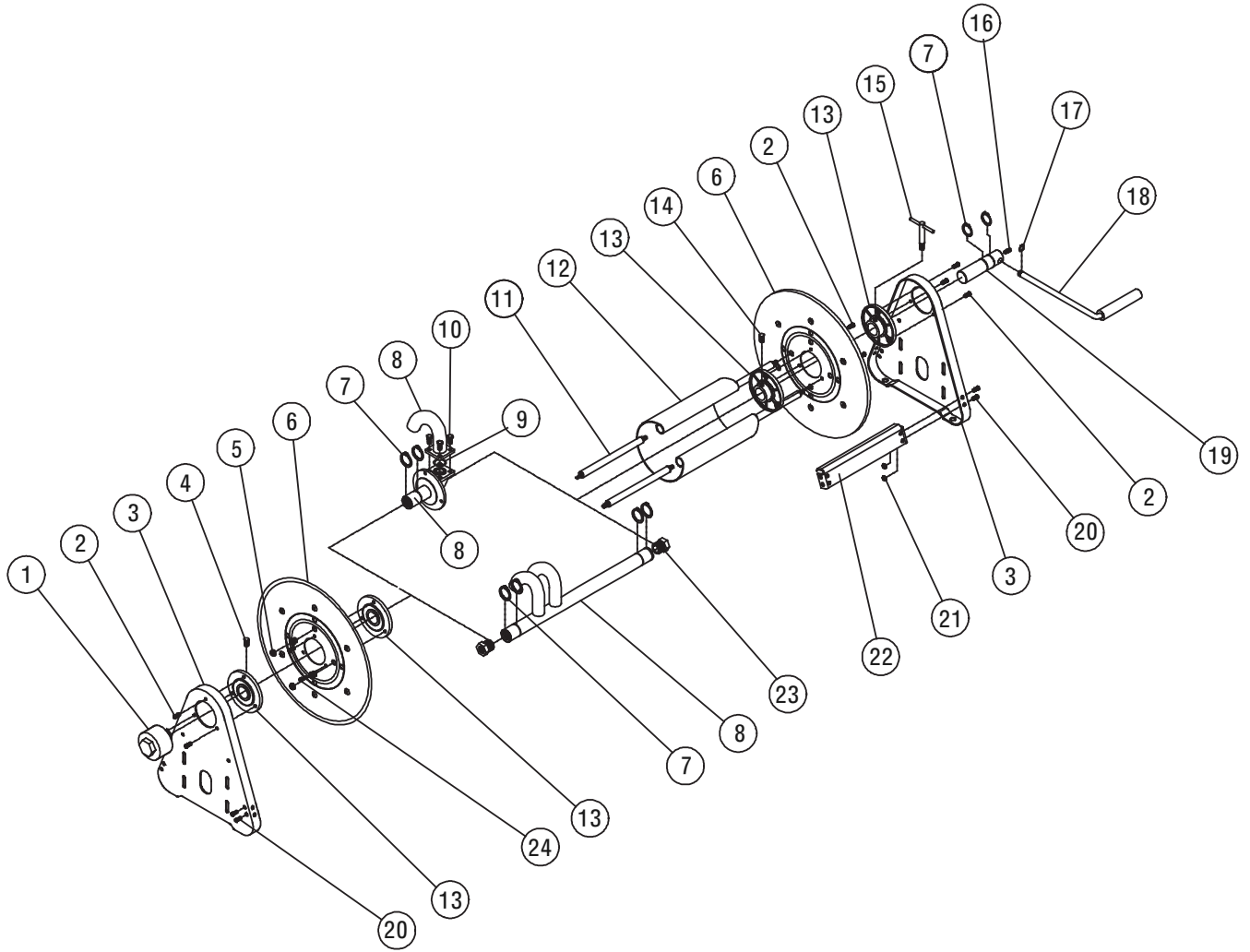

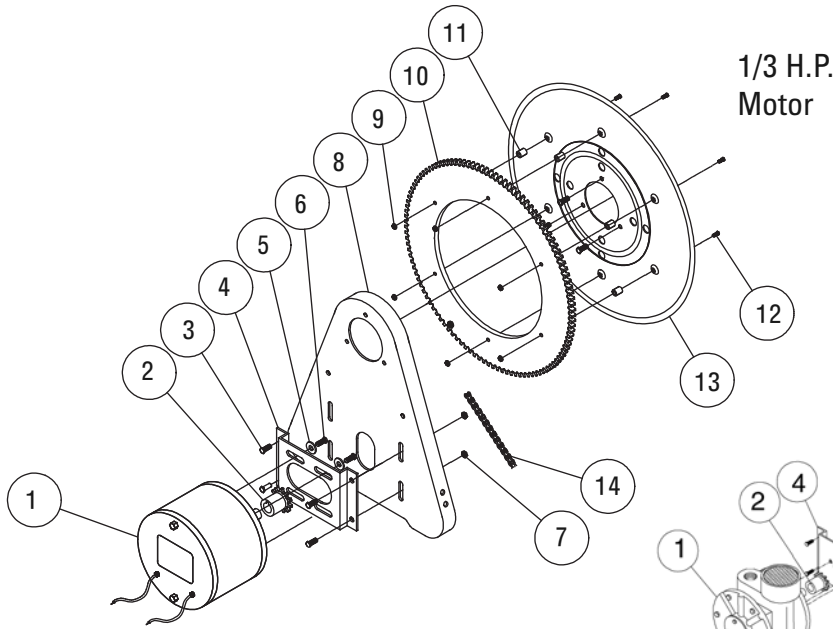

1/3 H.P. Motor

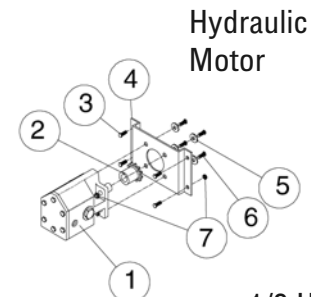

Hydraulic Motor

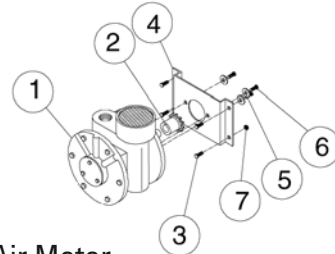

Air Motor

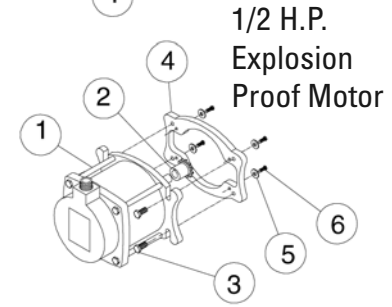

1/2 H.P. Explosion Proof Motor

**Parts common to all motorized Series 30000 hose reels**

ITEM	PART NO.	DESCRIPTION	QTY.
8	260403 REF.	Side frame	-
9	S79-3	Flange nut 10-32	6
10	260407	Spool gear	1
11	260410	Spacer, gear	6
12	S27-112	Screw 10-31 x 1 1/8"	6
13	260399-3 REF.	Spool flange	-
14	260406	Chain, drive #35	1

**Parts common to air motor driven Series 30000 hose reels** (reference model number significance)

ITEM	DESCRIPTION	QTY.	X4A	X6A
1	Drive motor	1	260428	260429
2	Gear, motor	1	260436	260408
3	Screw 5/16 -18 x 5/8"	4	S2-52	S2-52
4	Bracket, motor	1	260405	260433
5	Washer	11	300039	300039
6	Screw 5/16-18 x 5/8"	6	S2-42	S2-51
7	Lock nut 5/16-18	12	S85-7	S85-7

**Parts common to 1/2 horse power explosion proof motor driven Series 30000 hose reels** (reference model number significance)

ITEM	DESCRIPTION	QTY.	X12DX	X24DX	X10AX
1	Drive motor	1	260583	260626	260430
2	Gear, motor	1	260434	260434	260434
3	Screw 3/8-16 x 3/4"	4	S44-3	S44-3	S44-3
4	Bracket, motor	1	260456	260456	260456
5	Washer	4	300039	300039	300039
6	Screw 5/16-18 x 5/8"	4	S2-52	S2-52	S2-52

**Parts common to 1/3 horse power motor driven Series 30000 hose reels**

(reference model number significance)

ITEM	DESCRIPTION	QTY.	X12D	X24D
1	Drive motor	1	260409	260450
2	Gear, motor	1	260408	260408
3	Screw 5/16-18 x 5/8"	4	S2-52	S2-52
4	Bracket, motor	1	260405	260405
5	Washer	4	300039	300039
6	Screw 5/16-18 x 5/8"	4	S2-52	S2-52
7	Lock nut 5/16-18	4	S85-7	S85-7

**Parts common to hydraulic driven Series 30000 hose reels** (reference model number significance)

ITEM	DESCRIPTION	QTY.	H3XXXX X
1	Drive motor	1	260553
2	Gear, motor	1	260436
3	Screw 5/16-18 x 5/8"	4	S2-52
4	Bracket, motor	1	260405
5	Washer	4	300039
6	Screw 5/16-18 x 5/8"	4	S2-53
7	Lock nut 5/16-18	8	S85-7